

SAMOZAMYKACZ GEZE - INSTRUKCJA MONTAŻU

TS 2000 NV BC

technika
progowa



//ALUMASTER®
WINDOWS AND DOORS SOLUTIONS

Akcesoria drzwiowe

GEZE TS 2000 NV BC

CHARAKTERYSTYKA

- Bezstopniowa regulacja siły w zakresie 2-4 (zgodnie z PN-EN 1154)
- Regulowana z przodu prędkość zamykania oraz końcowa faza zamykania (dobicie)
- Regulowane z przodu tłumienie otwierania od kąta około 65° (tzw. funkcja „antywiatrowa”)
- Odporność na korozję – bardzo wysoka (klasa 4 zgodnie z PN-EN 1670)
- Trwałość funkcji samoczynnego zamykania – 500 000 cykli (klasa 8 zgodnie z PN-EN 1154)
- Standard wykończenia - srebrny EV1
- Na zamówienie dostępny w kolorze stali nierdzewnej, ciemnym brązie i kolorach z palety GEZE RAL

ZASTOSOWANIE

- Do drzwi rozwieranych 1-skrzydłowych o szerokości skrzydła do 1100 mm
- Do drzwi przeciwpożarowych i dymoszczelnych – siła 3 (zgodnie z PN-EN 1154)

MONTAŻ

- Standardowy - na skrzydle drzwiowym po stronie zawiasów
- Odwrócony - na ościeżnicy po stronie przeciwnej do zawiasów
- Na skrzydle po stronie przeciwnej do zawiasów z ramieniem równoległym

WYMIARY SAMOZAMYKACZA

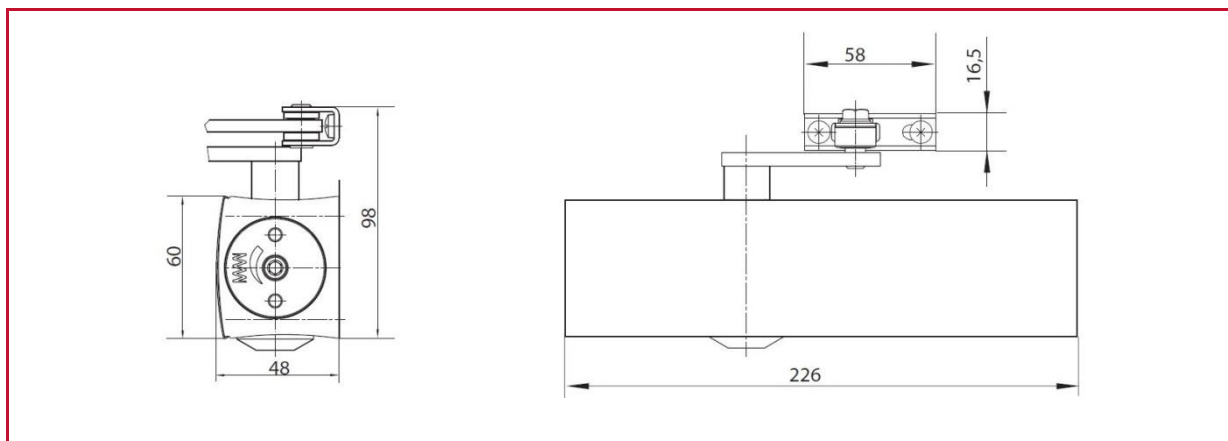

WYMIARY PŁYTKI MONTAŻOWEJ TS 2000 NV

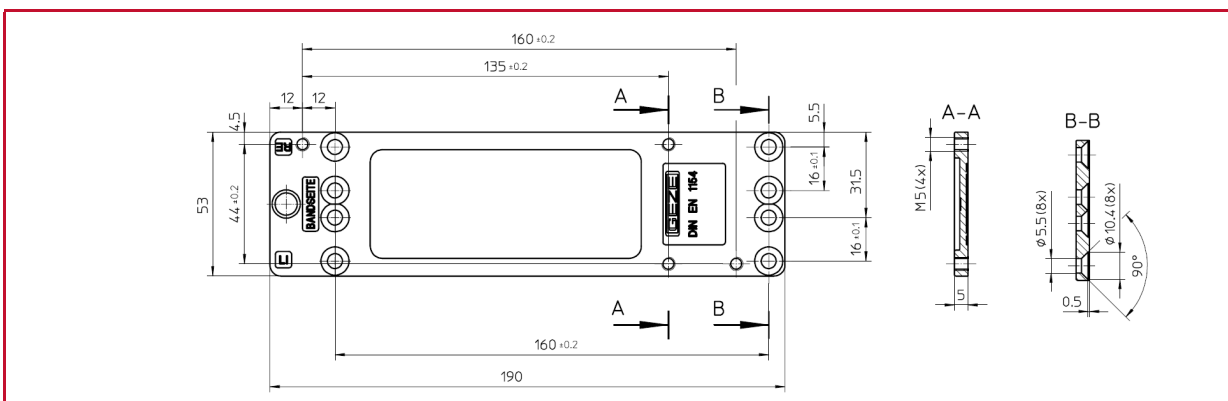

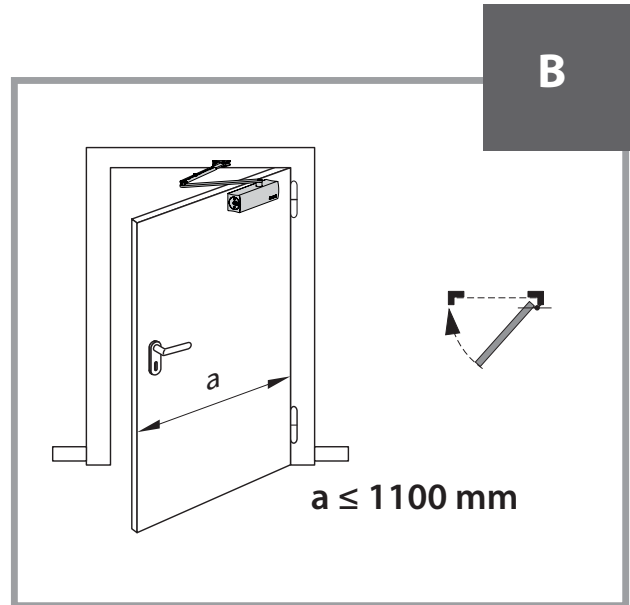
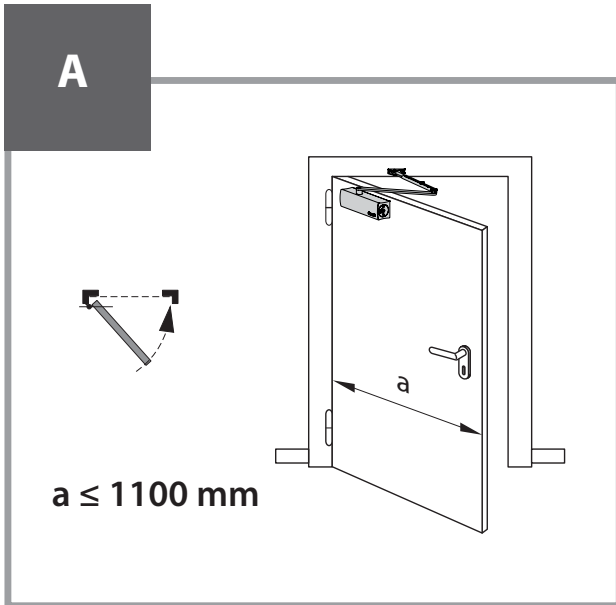

MONTAŻ BEZ PŁYTKI MONTAŻOWEJ

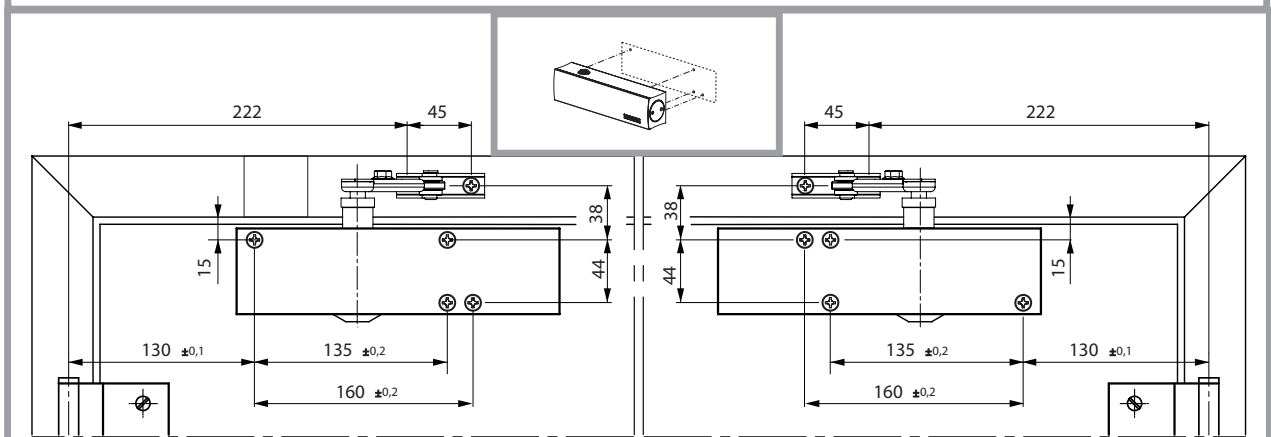
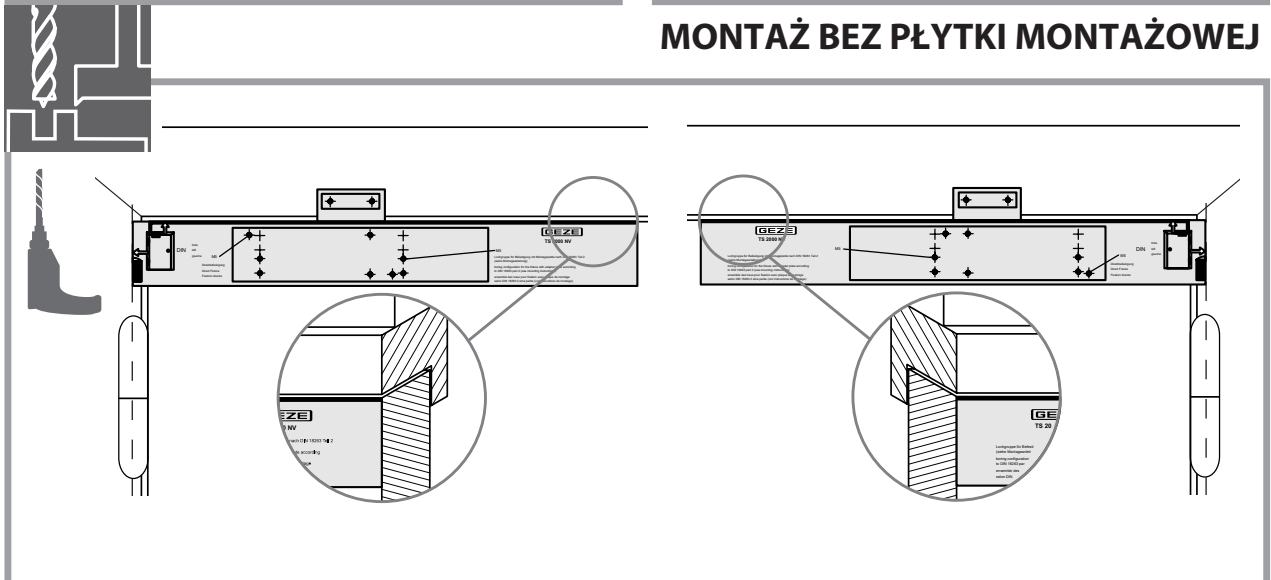

- 4x 5x70
- 4x M5x55

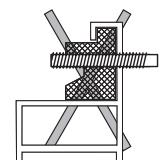
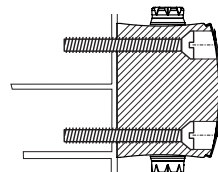
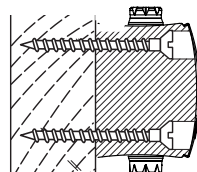

MONTAŻ Z PŁYTKĄ MONTAŻOWĄ

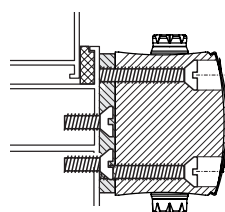
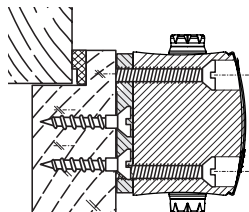
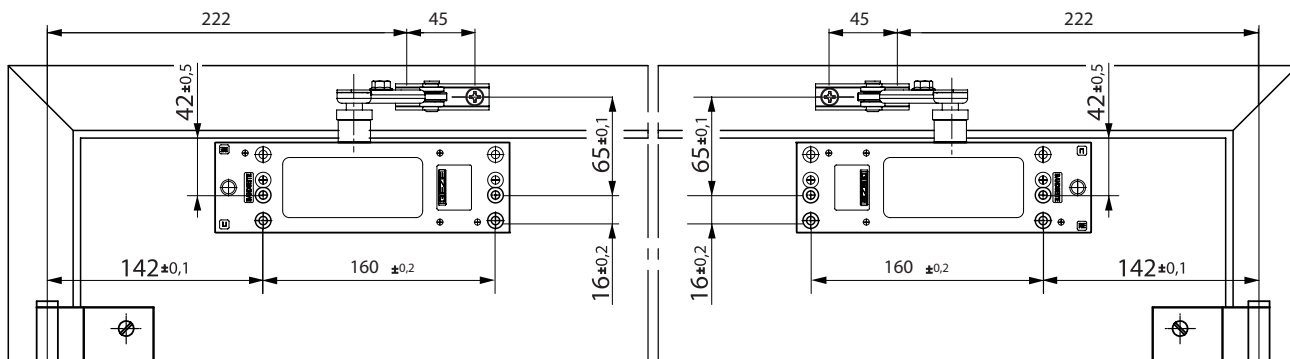
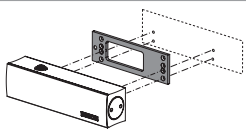

1

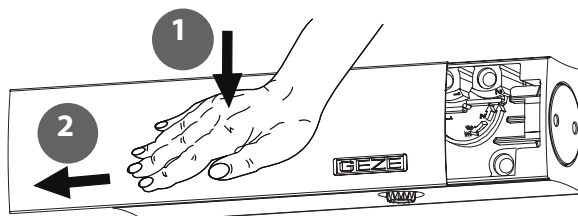

2

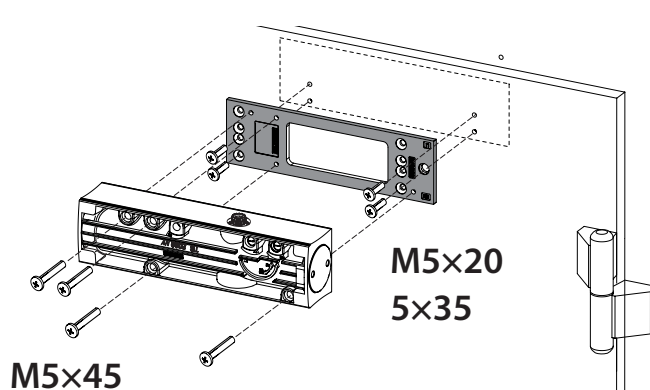
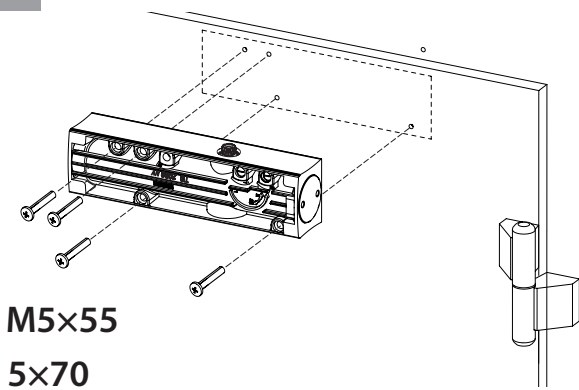

3

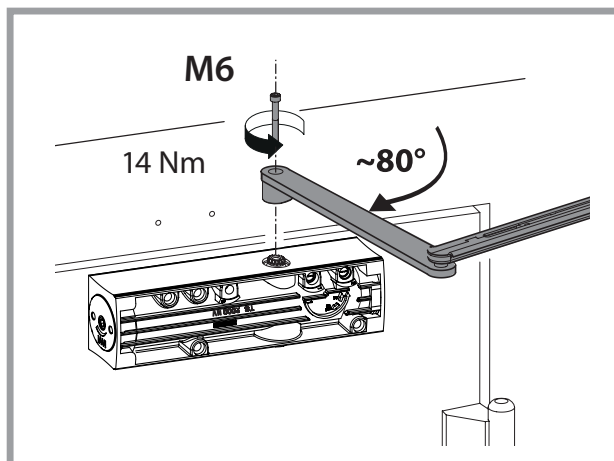
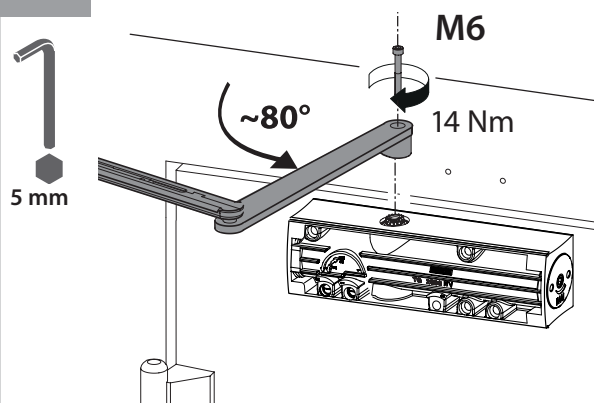

4

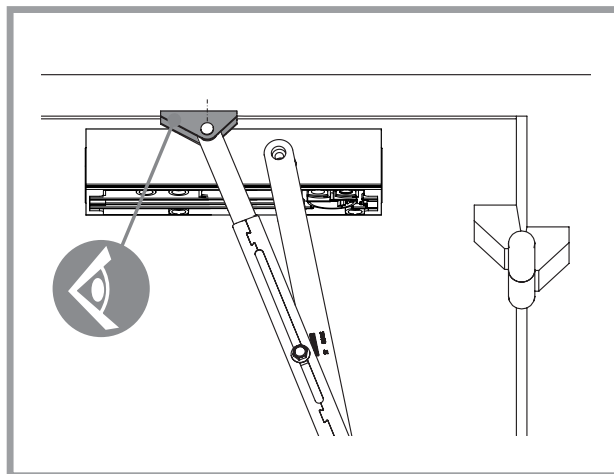
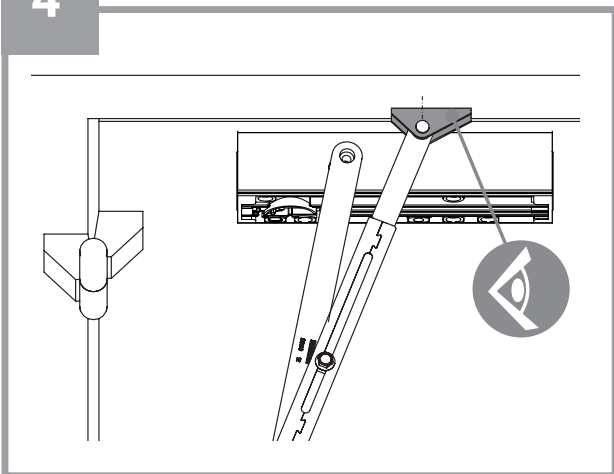

5

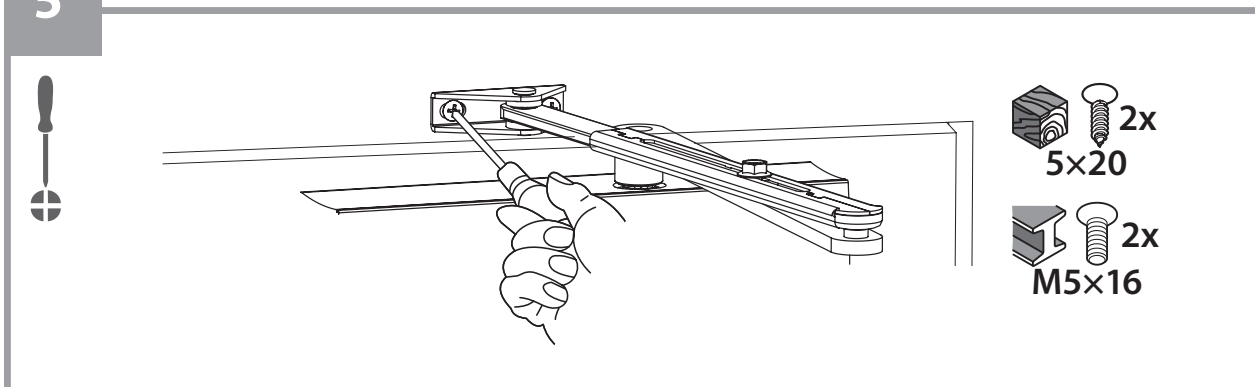

6

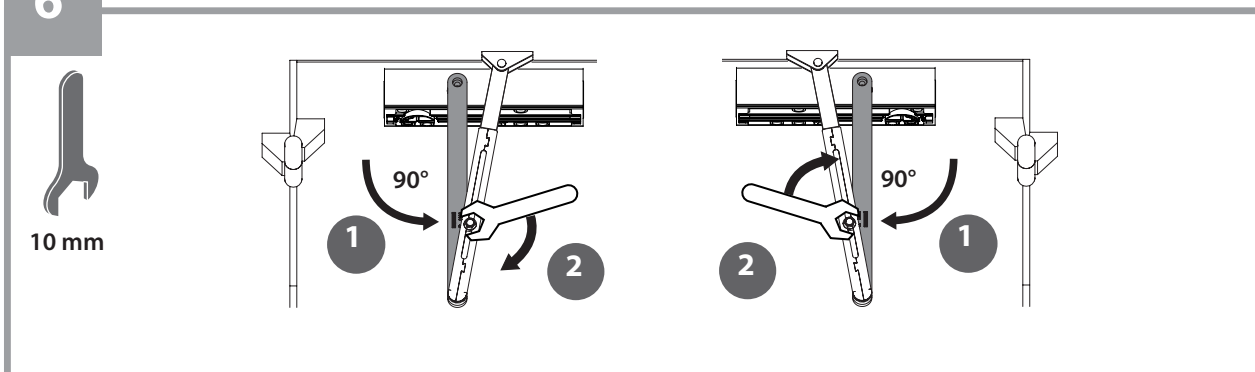

7

5 mm

a

a (mm)	1x	2x	3x	4x	5x	6x	7x	8x
1100	1	2	3	4	5	6	7	8
950	1	2	3	4	5	6	7	8
850	1	2	3	4	5	6	7	8
750	1	2	3	4	5	6	7	8

EN 1154

8

TS 2000 NV

90° 7s



TS 2000 NV BC

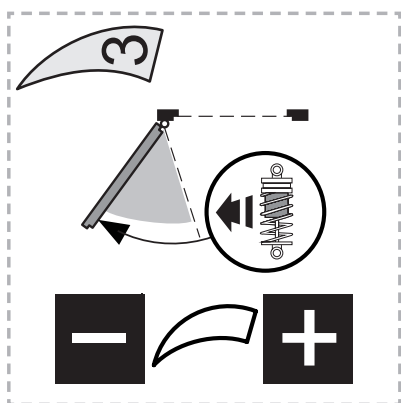
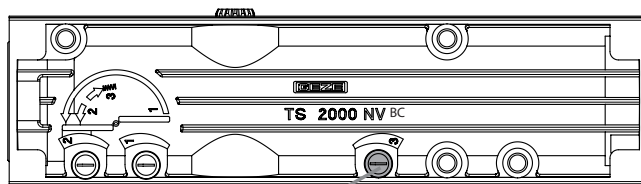

9

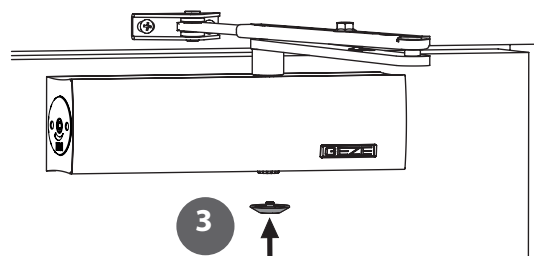
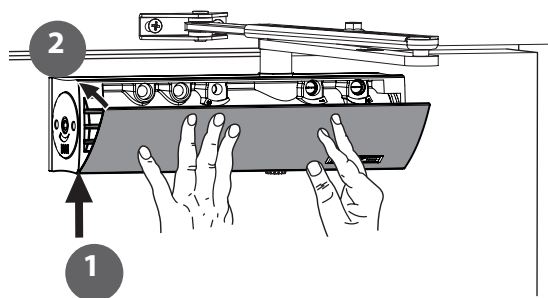

$a \leq 1100 \text{ mm}$

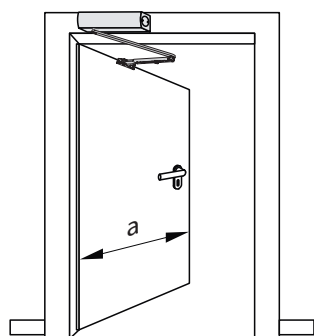

$a \leq 1100 \text{ mm}$

